



Features and Benefits

- Oil cleanliness codes: ISO 4406, NAS 1638, SAE AS4059
- Particles are grouped by micron size in seven categories - 4, 6, 14, 21, 38, 70, >100µ
- The S120 counts air and gas bubbles and eliminates them from the counts.
- The shape recognition software is able to categorize particulate into sliding, cutting and fatigue wear.
- Highly accurate sensor capable of self-calibration
- Full integration with SCADA/PC/PLC which can be controlled via analogue or digital instrumentation

Applications

- Mobile Equipment Technology
- Monitoring of Oil Cleanliness in Storage Tanks
- Surface Mining
- Construction
- Fleet Services

The S120 digital imaging particle counter is a revolutionary sensor capable of counting a broad spectrum of particles, recognizing shapes, and eliminating air bubbles from the counts. Many years of research and development have gone into this new sensor.

Digital imaging particle counting provides engineers with a deeper insight into their oils. The sensor has the ability to measure a broad spectrum from 4 to > 100µ recognizing different shapes of particles which can be grouped into fatigue wear, sliding wear and cutting wear as well as fibers.

Information is displayed on an interactive 4.3" LCD touchscreen displaying all information with a graph showing oil cleanliness over time. Water content is displayed as % saturation (relative humidity) and helps inform when an oil change is required.

Description

Specifications

Voltage:	24VDC or 120VAC (see Model Code)
Working Pressure:	5 Bar (72 psi)
Flow Rate:	0.03-0.13 gpm (0.1-0.5 l/min)
Viscosity Limit:	2270 SUS (460 cSt)
Seal Material:	Viton
Bypass Setting:	N/A
Horsepower:	50-Watts (24VDC Motor)
Fluid Compatibility:	<ul style="list-style-type: none"> • Mineral Oils • Synthetic Oils • Diesel • Other fluids possible; please contact us for more information
Weight:	11.5 - 56.0lbs
Dimensions with Frame:	23.0" x 9.92" x 20.67"
Ambient Temperature Range:	40°-104°F (4°-40°C)
Fluid Temperature Range:	32°-140°F (0°-60°C)
Output Options:	<ul style="list-style-type: none"> • Modbus RTU (RS485) • Modbus TCP/IP • Local panel mount indicator • Local field mount indicator

Model Number Selection

How to Build a Valid Model Number for a Schroeder HY-HV-S120:

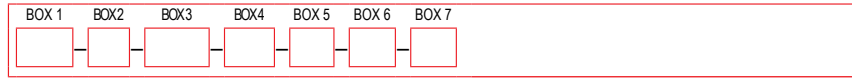

Example: NOTE: One option per box

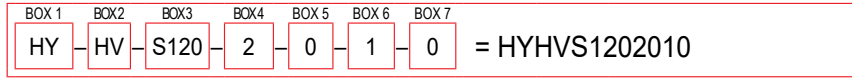

BOX 1	BOX 2	BOX 3	BOX 4	BOX 5
Model	Viscosity	Particle	Display	Fluid Type
HY	HV = High Viscosity	S120	1 = w/o 2 = w/ display	0 = Hydraulic/Mineral Oil

BOX 6	BOX 7
Power	Water Sensor
0 = No Controls & No Frame 1 = 120VAC & Frame	0 = No Water Sensor AS = AS1000 ASD = AS3000

Particle Counter WITHOUT Display HY-HV-S120-1-0-1-0

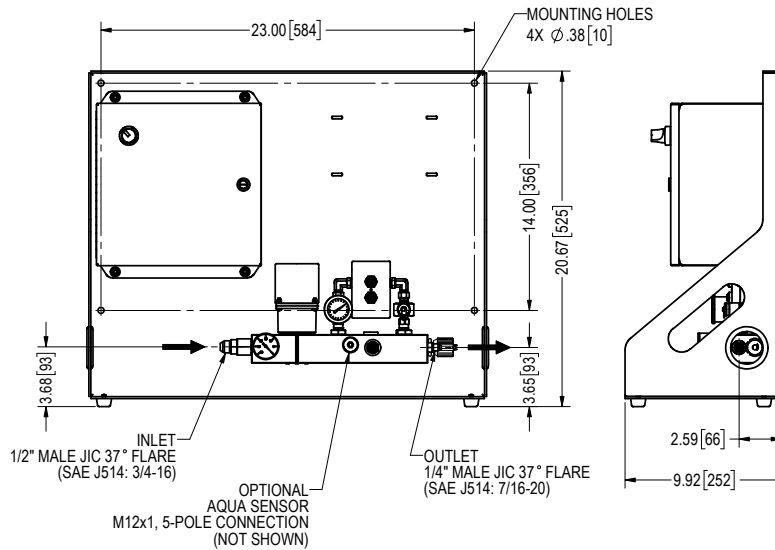

Particle Counter WITH Display HY-HV-S120-2-0-1-0

